

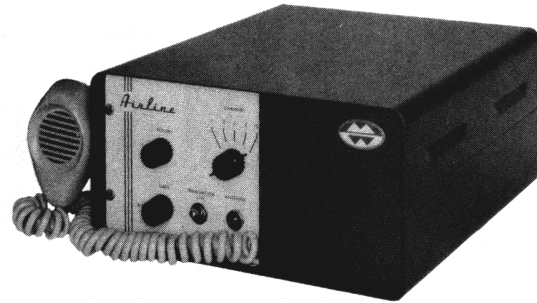

# PHOTOFACT<sup>®</sup>

TRADE NAME : Airline Model GAS-587  
 SUPPLIER : Montgomery Ward & Co.,  
 619 Chicago Ave., Chicago 7, Illinois  
 TYPE SET : 9 Tube Citizens Band Transceiver  
 POWER SUPPLY : 110 - 120 Volts AC, 60 Cycles (or)  
 12 VDC (or) 32 VDC  
 RATING : 50 Watts, .45 Amp. @117 Volts AC  
 TUNING RANGE : Any 5 of Citizens Band Channels 1 thru 22



## ALIGNMENT INSTRUCTIONS

### RECEIVER ALIGNMENT

Output meter across voice coil.  
 Volume control should be at maximum position. Output of signal generator should be no higher than necessary to obtain an output reading.

SIGNAL GENERATOR	CHANNEL	ADJUST	REMARKS
High side thru .1mfd to pin 2 of V2, low side to chassis. (Tune to 455KC 400% Mod.)	Any	A1, A2, A3, A4	Adjust for maximum.
Across antenna terminal. (Tune to channel freq.)	Center Channel Used.	A5, A6, A7	Adjust for maximum.

### TRANSMITTER ALIGNMENT

ONLY THOSE PERSONS PROPERLY LICENSED ARE PERMITTED TO MAKE REPAIRS OR ADJUSTMENTS WHICH MAY RESULT IN ILLEGAL OPERATION. (REFER TO FCC RULES & REGULATIONS PART 19, SUBPART D, SECTION 19.71)

INDICATOR	ADJUST	REMARKS
Accurate frequency measuring device.	A8	Adjust for exact frequency of center channel used.
DC VTVM connected from pin 7 (grid) of V7 to chassis.	A9	Adjust for maximum deflection, then back off just below peak on side of gradual dropoff.
"	A10	Adjust for maximum deflection.
Panel lamp and DC milliammeter connected to 2-screw terminal strip on top side of chassis.	All, A12, A13	Preset All nearly snug. Adjust A12 for MINIMUM. Connect antenna. Adjust A13 for maximum front panel lamp brilliance. Meter should indicate 25MA. If not, disconnect antenna, rotate A11 counterclockwise a turn. Adjust A12 for MINIMUM. Connect antenna. Adjust A13 for maximum lamp brilliance. If meter does not indicate 25MA, repeat procedure. If more than 25MA is indicated, increase capacity of A11 and readjust A12 and A13.

AIRLINE MODEL GAS-587

**HOWARD W. SAMS & CO., INC.** Indianapolis 6, Indiana

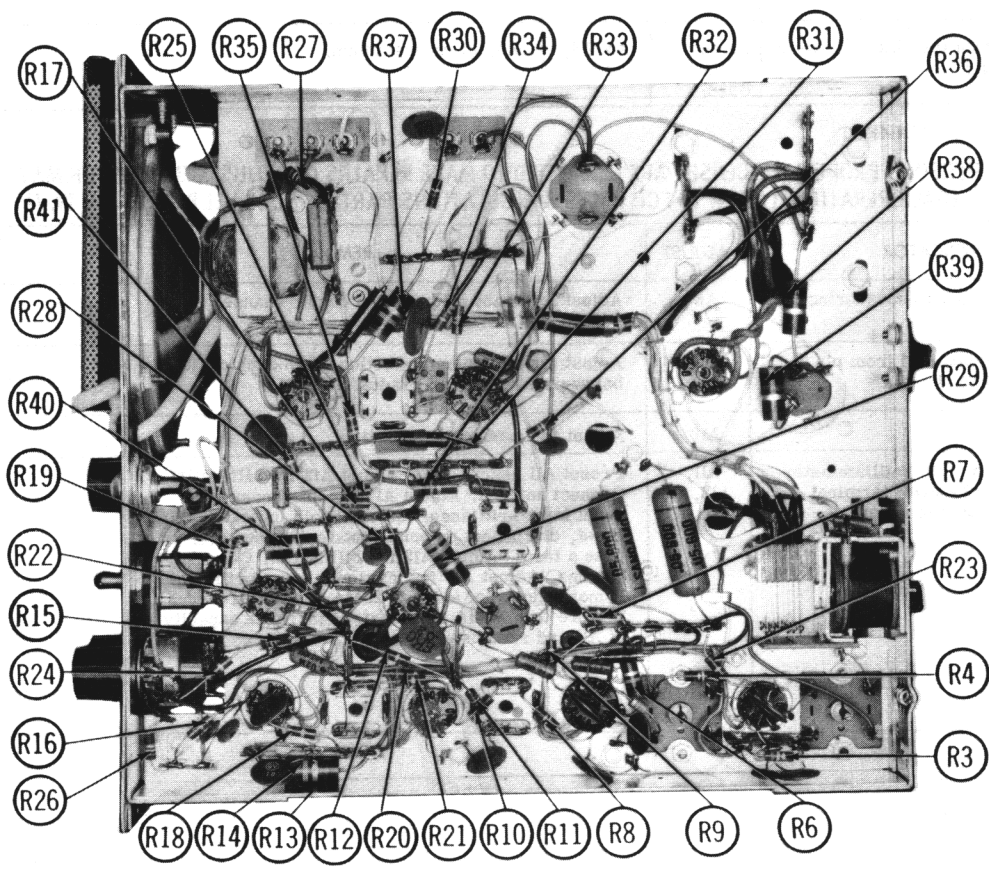
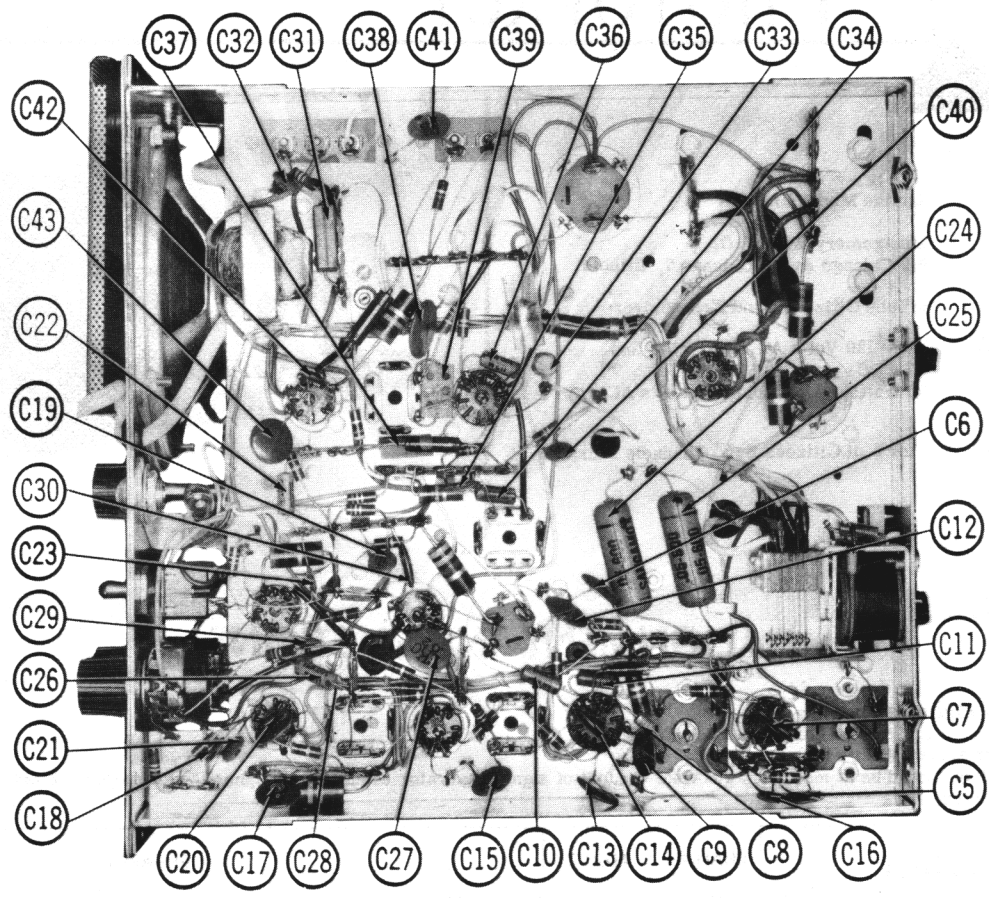

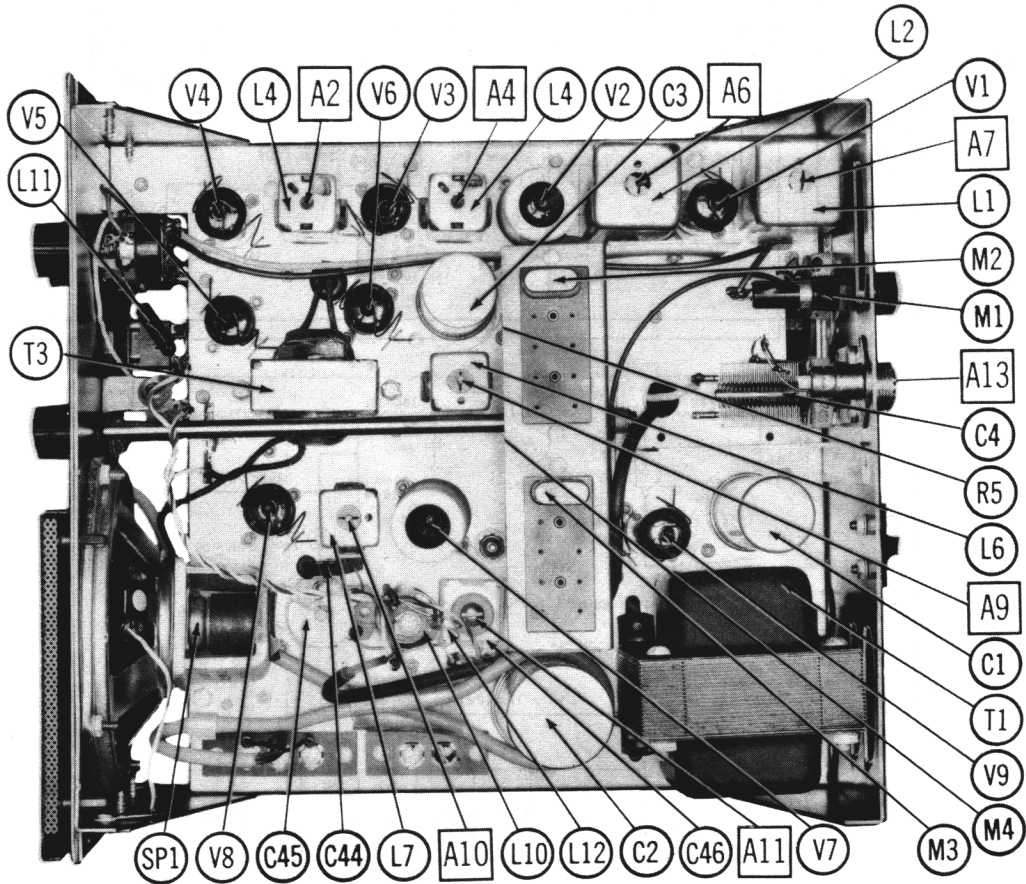
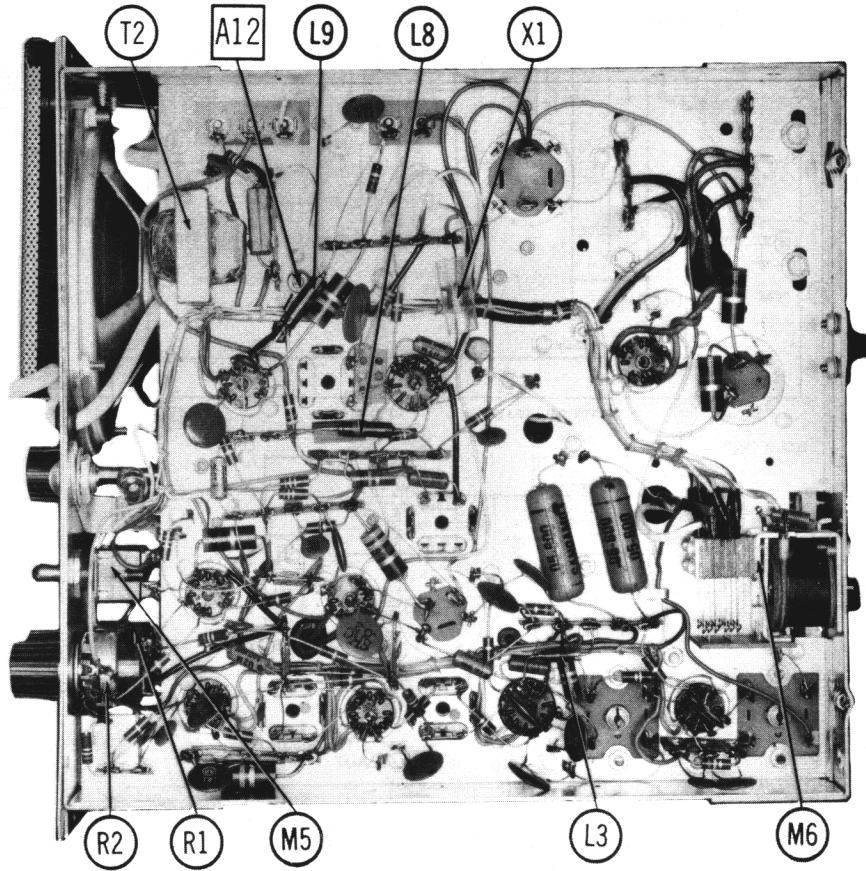

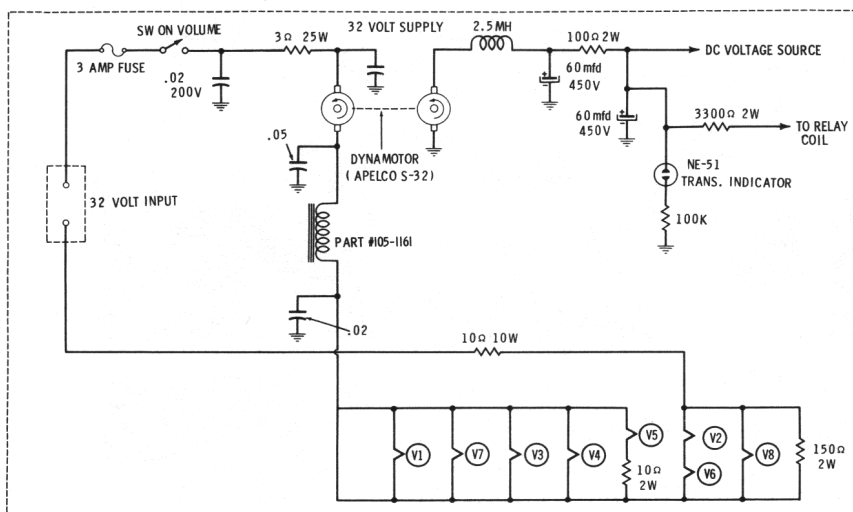
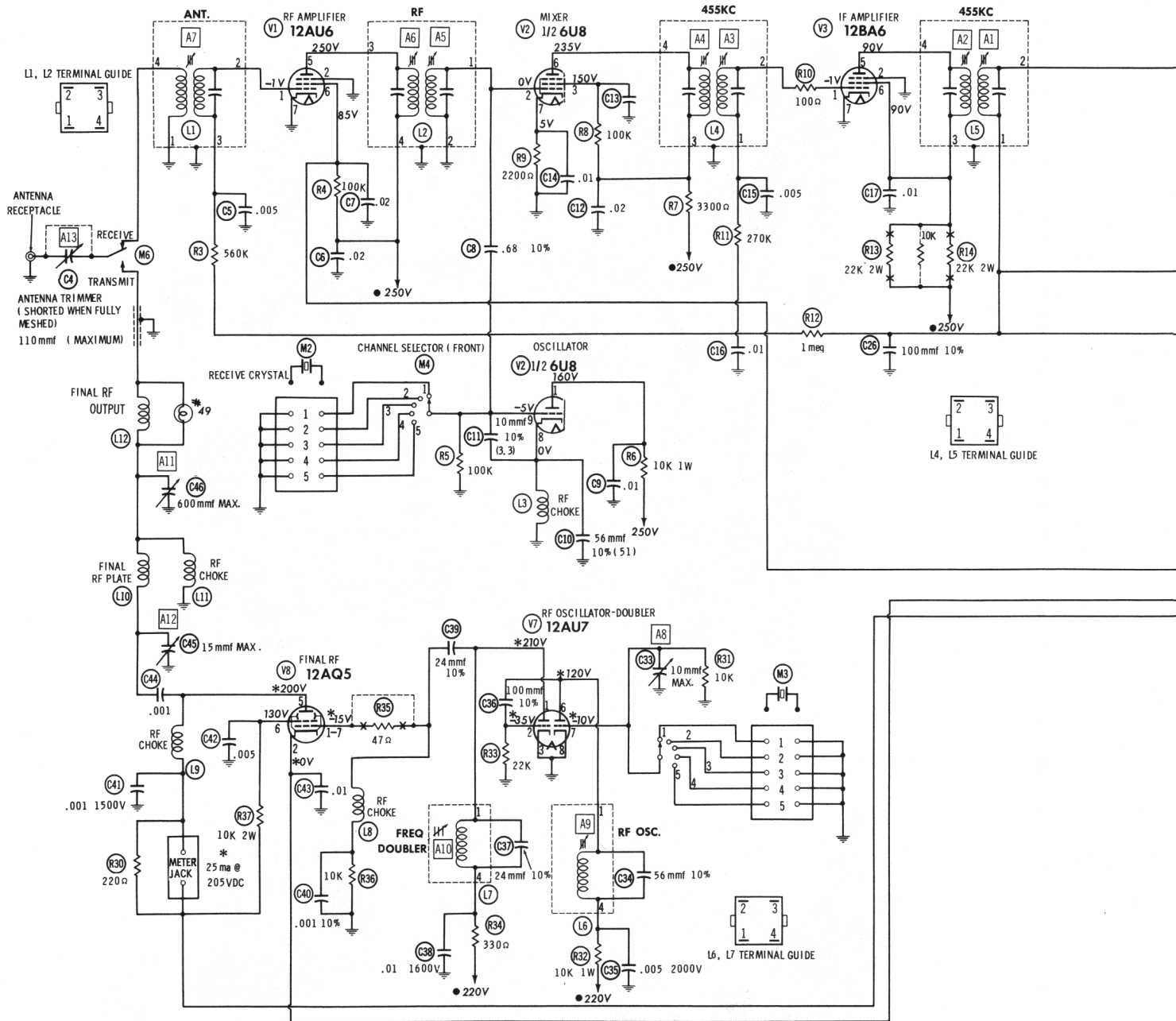

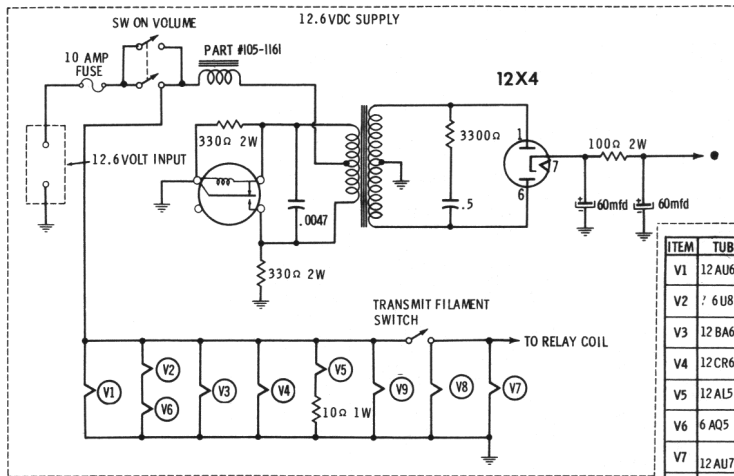
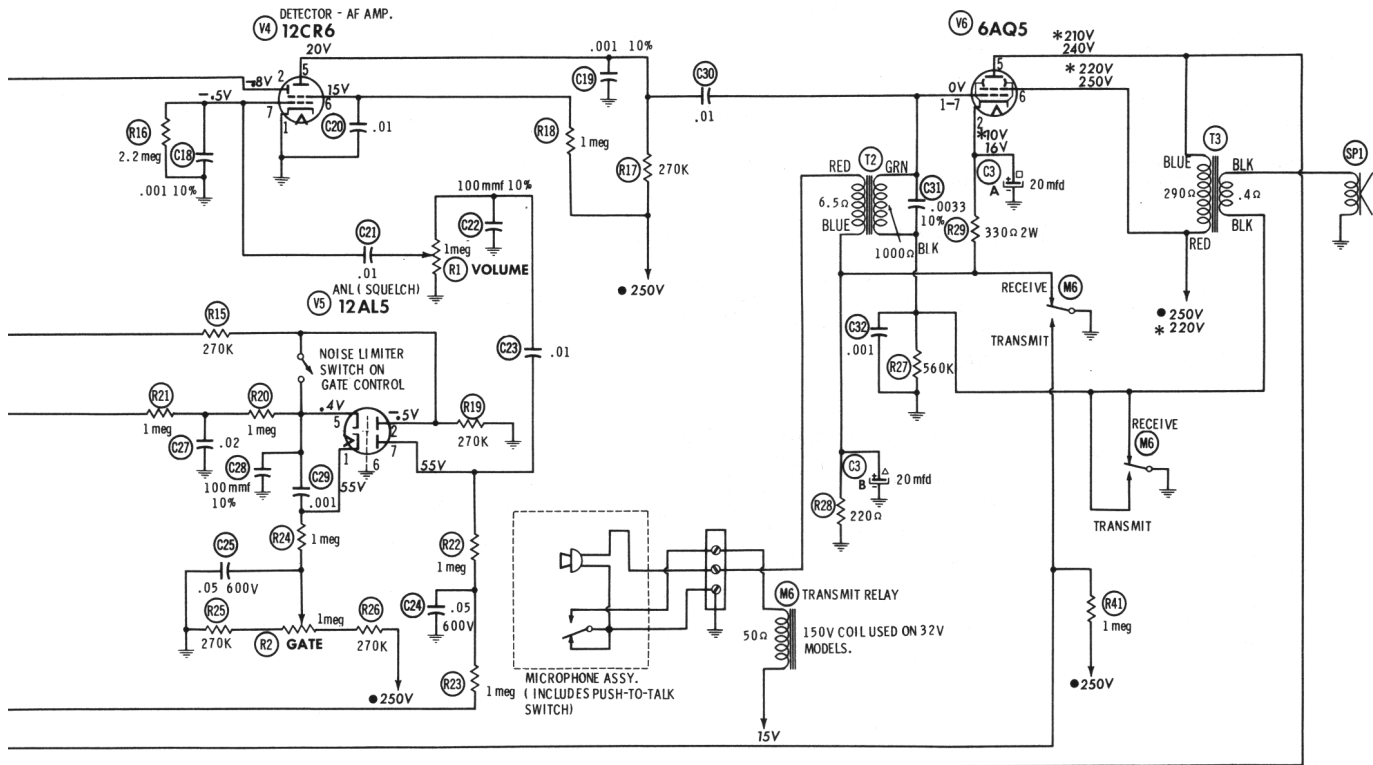

- ⊖ See parts list for alternate value or application.
- 1. Voltage measurements taken with vacuum tube voltmeter.
- 2. All controls set for normal operation, no signal applied.
- 3. Measured values are from socket pin or terminal to common ground.
- 4. All terminals viewed from bottom unless otherwise designated.
- 5. Numbers assigned to terminals may not be found on the unit.
- 6. Supply voltage maintained at rated value for voltage readings.

RESISTANCE READINGS

ITEM	TUBE	Pin 1	Pin 2	Pin 3	Pin 4	Pin 5	Pin 6	Pin 7	Pin 8	Pin 9
V1	12AU6	2 meg	0 Ω	FIL	FIL	†200 Ω	†100K	0 Ω		
V2	6U8	†10.2K	0 Ω	†100K	FIL	FIL	†3500 Ω	2200 Ω	0 Ω	100K
V3	12BA6	2 meg	0 Ω	FIL	FIL	†11.2K	†11.2K	0 Ω		
V4	12CR6	0 Ω	540K	FIL	FIL	†270K	†1 meg	2.2 meg		
V5	12AL5	†1.2 meg	270K	FIL	FIL	2.5 meg	0 Ω	†2.1 meg		
V6	6AQ5	560 Ω	330 Ω	FIL	FIL	†465 Ω	†200 Ω	560 Ω	820 Ω	
V7	12AU7	††550 Ω	22K	0 Ω	FIL	FIL	††10.2K	10K	0 Ω	FIL
V8	12AQ5	NC	*0 Ω	FIL	FIL	†685 Ω	†10.2K	10K		
V9	12X4	150 Ω	TP	FIL	FIL	TP	150 Ω	†		

† THIS READING WILL VARY DEPENDING UPON THE CONDITION OF THE ELECTROLYTIC IN THE CIRCUIT.  
 † MEASURED FROM PIN 7 OF V9. \* MEASURED IN "TRANSMIT" POSITION.  
 NC. NO CONNECTION TP. TIE POINT

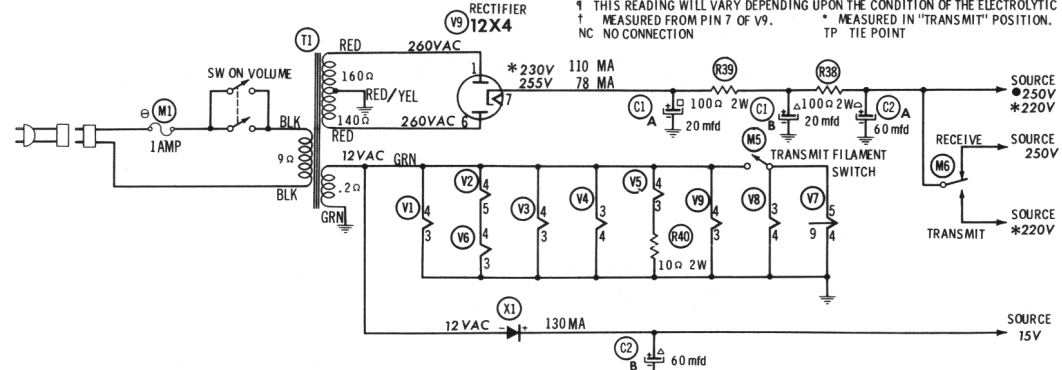

A PHOTOFAC STANDARD NOTATION SCHEMATIC  
 ©Howard W. Sams & Co., Inc. 1963

**AIRLINE MODEL GAS-587**

# PARTS LIST AND DESCRIPTION

## TUBES

ITEM No.	USE	REPLACEMENT DATA			ITEM No.	USE	TYPE
		AMPEREX	GENERAL ELECTRIC	RCA			
V1	RF Amplifier		12A U6		V6	Output - Modulator	6AQ5
V2	Mixer - Oscillator		6U8		V7	Oscillator - Doubler	12AU7
V3	IF Amplifier		12BA6		V8	Final Amplifier	12AQ5
V4	Detector - AF Amp.		12CR6		V9	Rectifier	12X4
V5	ANL - Squelch		12AL5				

## POWER RECTIFIERS & SIGNAL DIODES

ITEM No.	MEASURED CURRENT	ORIGINAL Part or Type No.	RECTIFIERS			NOTES
			MALLORY PART No.	RCA PART No.	SARKES TARZIAN PART No.	
X1	130MA	PT-5	1N2070	1N3194	F4	AC Versions only.

## ELECTROLYTIC CAPACITORS

ITEM No.	RATING		REPLACEMENT DATA						
	CAP.	VOLT.	AIRLINE PART No.	AEROVOX PART No.	CORNELL-DUBILIER PART No.	GENERAL ELECTRIC PART No.	GENERAL INSTRUMENT PART No.	MALLORY PART No.	SPRAGUE PART No.
C1A	20	450		AFH2-51	B0390	XC2-15	TMD-2625	FP234A	TVL-2755
B	20	450							
C2A	60	450		AFH2-59	B0464	XC2-33	TMD-2670	FP148/TC795	TVL-2772
B	60	450							
C3A	20	100		AFH2-08	B0090	XC2-13	TMD-2075	FP208A	TVL-2415
B	20	100							

## FIXED CAPACITORS

ITEM No.	RATING	REMARKS	REPLACEMENT DATA						
			AEROVOX PART No.	CENTRALAB PART No.	CORNELL-DUBILIER PART No.	ELMENCO PART No.	MALLORY PART No.	SPRAGUE PART No.	
C4	110 (max.)	#24E16-2							
C5	.005		BPD-005	DD-502	BYA10D5	CCD-502	B-250		5HK-D50
C6	.02		BPD-02	DD-203	BYB6S2	CCD-203	B-120		5HK-S20
C7	.02		BPD-02	DD-203	BYB6S2	CCD-203	B-120		5HK-S20
C8	.68 10%		NPO-SI .68	TCZ-R68					
C9	.01		BPD-01	DD-103	BYA10S1	CCD-103	B-110		5HK-S10
C10	56 10%	(51) †	NPO-SI 56	D6-560	L10Q56	CCD-560	GP456		10TS-Q56
C11	10 10%	(3.3) †	NPO-SI 10	D6-100	L10Q1	CCD-100	GP410		10TS-Q10
C12	.02		BPD-02	DD-203	BYB6S2	CCD-203	B-120		5HK-S20
C13	.02		BPD-02	DD-203	BYB6S2	CCD-203	B-120		5HK-S20
C14	.01		BPD-01	DD-103	BYA10S1	CCD-103	B-110		5HK-S10
C15	.005		BPD-005	DD-502	BYA10D5	CCD-502	B-250		5HK-D50
C16	.01		BPD-01	DD-103	BYA10S1	CCD-103	B-110		5HK-S10
C17	.01		BPD-01	DD-103	BYA10S1	CCD-103	B-110		5HK-S10
C18	.001 10%		DI-1000	DD-102	5R5D1	CCD-102	GP210		10TS-D10
C19	.001 10%		DI-1000	DD-102	5R5D1	CCD-102	GP210		10TS-D10
C20	.01		BPD-01	DD-103	BYA10S1	CCD-103	B-110		5HK-S10
C21	.01 50V		TTD-01	CK-103	H05S1	CCD-103	TA-110		5HK-S10
C22	100 10%		NPO-SI 100	D6-101	L10T1	CCD-101	GP310		10TS-T10
C23	.01		BPD-01	DD-103	BYA10S1	CCD-103	B-110		5HK-S10
C24	.05 600V		P688N-047	DD-503	CUB6S47	6DP-3-473	GEM-6147		6TM-S47
C25	.05 600V		P688N-047	DD-503	CUB6S47	6DP-3-473	GEM-6147		6TM-S47
C26	100 10%		NPO-SI 100	D6-101	L10T1	CCD-101	GP310		10TS-T10
C27	.02	(.01) †	BPD-02	DD-203	BYB6S2	CCD-203	B-120		5HK-S20
C28	100 10%		NPO-SI 100	D6-101	L10T1	CCD-101	GP310		10TS-T10
C29	.001		EF-001	MFT-1000		CCF-102	CT280A		
C30	.01		BPD-01	DD-103	BYA10S1	CCD-103	B-110		5HK-S10
C31	.0033 10%		1469-0033		1R5D33	CM-20B-332K	MCJ462		MS-233
C32	.001		EF-001	MFT-1000		CCF-102	CT280A		
C33	10 (Max.)								
C34	56 10%		NPO-SI 56	D6-560	L10Q56	CCD-560	GP456		10TS-Q56
C35	.005 2000V		DD30-502		HVC20D5	3CCD-502	2HV-247		BL-D50
C36	100 10%		NPO-SI 100	D6-101	L10T1	CCD-101	GP310		10TS-T10
C37	24 10%		1469-000024	TCZ-24	22R5Q24	CM-19B-240K	MCB-220		MS-424
C38	.01 1600V		DAC-27	DD16-103	HVE16S1	16DP-3-103	UAC-110		BL-S10
C39	24 10%		1469-000024	TCZ-24	22R5Q24	CM-19B-240K	MCB-220		MS-424
C40	.001 10%		DI-1000	DD-102	5R5D1	CCD-102	GP210		10TS-D10
C41	.005	(.01) †	BPD-005	DD-502	BYA10D5	CCD-502	B-250		5HK-D50
C42	.001 1500V		DAC-2	DD30-102	HVB20D1	3CCD-102	UAC-210		BL-D10
C43	.01		BPD-01	DD-103	BYA10S1	CCD-103	B-110		5HK-S10
C44	.001		EF-001	MFT-1000		CCF-102	CT280A		
C45	15 (Max.)	#CT3-0-21SP							
C46	600 (Max.)	#CHC-482002							

† Alternate Value.  
# Airline Part Number.

## CONTROLS

All wattages 1/2 watt, or less, unless otherwise listed.

ITEM No.	USE	RESISTANCE	REPLACEMENT DATA				
			AIRLINE PART No.	CENTRALAB PART No.	CLAROSTAT PART No.	CTS-IRC PART No.	MALLORY PART No.
R1	Volume Power Switch	1meg	CM-16666	B-70-S or (F2-1meg, SU204, KR-4)	A-47-1meg-Z, FS-3, SWE-20	Q13-137, 76-2	(UA16A, SF1000, US-41) or (RU16A, SF1000, SL38, US42)
R2	Gate Control Noise Limiter Switch	1meg	CM-18888	B-70-S or (F2-1meg, SU204, KR-1)	A-47-1meg-Z, FS-3, SWE-12	Q13-137, 76-1	(U-53, US-26) or (UA16A, SF1000, US-41) or (RU16A, SF1000, SL38, US-41)

# PARTS LIST AND DESCRIPTION (CONTINUED)

## COILS (RF-IF)

ITEM No.	USE	REPLACEMENT DATA					NOTES
		AIRLINE PART No.	MERIT PART No.	MILLER PART No.	STANCOR PART No.	WORKMAN PART No.	
L1	Antenna	TL-61					
L2	RF	TL-62					
L3	RF Choke (1.5uh)	207-11	BC-562	4604	RTC-8516	T856	
L4	IF Input	TL-34	BC-352	12-C1	RTC-8632	T607	
L5	IF Output	TL-35	BC-352	12-C2	RTC-8633	T608	
L6	RF Oscillator	TL-65					
L7	Frequency Doubler	TL-64					
L8	RF Choke (21MH)	220-11	BC-565	4609	RTC-8519	T959	
L9	RF Choke (21MH)	220-11	BC-565	4609	RTC-8519	T959	
L10	Final RF Plate	TL-63					
L11	RF Choke (55MH)			4624	RTC-8524	T862	
L12	Indicator Coil						

## TRANSFORMER (POWER)

ITEM No.	RATING			REPLACEMENT DATA					NOTES
	PRI.	SEC. 1	SEC. 2	AIRLINE PART No.	MERIT PART No.	STANCOR PART No.	THORDARSON PART No.	TRIAD PART No.	
T1	117VAC @ .4A (.45A)*	520VCT @ .078A DC (.110A DC)*	13VAC @ 1.1A (1.6A)*	ST-89 † ST-86 *					† 117VAC Versions * 12VDC Versions * Transmit

## TRANSFORMER (MIC)

ITEM No.	TURNS RATIO		REPLACEMENT DATA					NOTES
	PRI.	SEC.	AIRLINE PART No.	MERIT PART No.	STANCOR PART No.	THORDARSON PART No.	TRIAD PART No.	
T2	1	35	ST-88					

## TRANSFORMER (AUDIO OUTPUT)

ITEM No.	IMPEDANCE		REPLACEMENT DATA					NOTES
	PRI.	SEC.	AIRLINE PART No.	MERIT PART No.	STANCOR PART No.	THORDARSON PART No.	TRIAD PART No.	
T3	5000Ω	3-4Ω	ST-19	A-2930	A-3877	24S51	S-3X	

## SPEAKER

ITEM No.	TYPE	REPLACEMENT DATA		NOTES
		AIRLINE PART No.	QUAM PART No.	
SP1	5" PM 3-4Ω	P5VA	5A05	

## FUSES

ITEM No.	TYPE	RATING	REPLACEMENT DATA					
			AIRLINE PART No.		LITTELFUSE PART No.		BUSS PART No.	
			FUSE	HOLDER	FUSE	HOLDER	FUSE	HOLDER
M1	3AG AGC MDL	1A 250V 10A 250V 3A	① ② ③		312001 (3AG 1A 250V) 312010 (AGC 10A)	342001 342001	AGC 1 AGC 10	HKP HKP

① AC Version. ② 12-Volt Versions. ③ 32-Volt Versions.

## VIBRATOR

ITEM No.	TYPE	INPUT VOLTS	FRE-QUENCY	REPLACEMENT DATA			NOTES
				AIRLINE PART No.	CORNELL-DUBILIER PART No.	MALLORY PART No.	
	Interrupter	12.6	115v	G-8301	6301	G-1601	12 Volt Versions only.

## MISCELLANEOUS

ITEM No.	PART NAME	AIRLINE PART No.	NOTES
M2	Crystal		Receive, Order by Channel Desired
M3	Crystal		Transmit, Order by Channel Desired
M4	Switch	50209-H	Crystal Selector (2 Pole, 5 Position Wafer Switch)
M5	Switch	SRP	Transmitter Filament (SPST Toggle Switch)
M6	Relay	5791A	Transmit-Receive (11 Volt)
	Knob	214	Channel Selector
	Knob	GR-RM	Volume, Gate

## WIRING DATA

General-use Hook-up Wire . . . . .	Use BELDEN No. 8530 (Solid) Available in 12 Colors 8524 (Stranded) Available in 12 Colors
Shielded Antenna Lead . . . . .	Use BELDEN No. 8214 Lowest Loss (RG-8/U Type) 8237 Low Loss (RG-8/U) 8240 (Solid) Miniature (RG-58/U) 8259 (Stranded) Miniature (RG-58A/U)
Coiled Microphone Cable . . . . .	Use BELDEN No. 8497 3 Conductor - 1 Shielded for Press-to-Talk (Neoprene) 8496 3 Conductor - 1 Shielded for Press-to-Talk (Vinyl)
Ignition Noise Suppression . . . . .	Use BELDEN No. 7300-Series Spark-Plug Sets
Bonding Strap . . . . .	Use BELDEN No. 8661 (3/8 In.)

AIRLINE MODEL GAS-587